

### 1.3.2

LX- CM002/ LX- CM004

mm

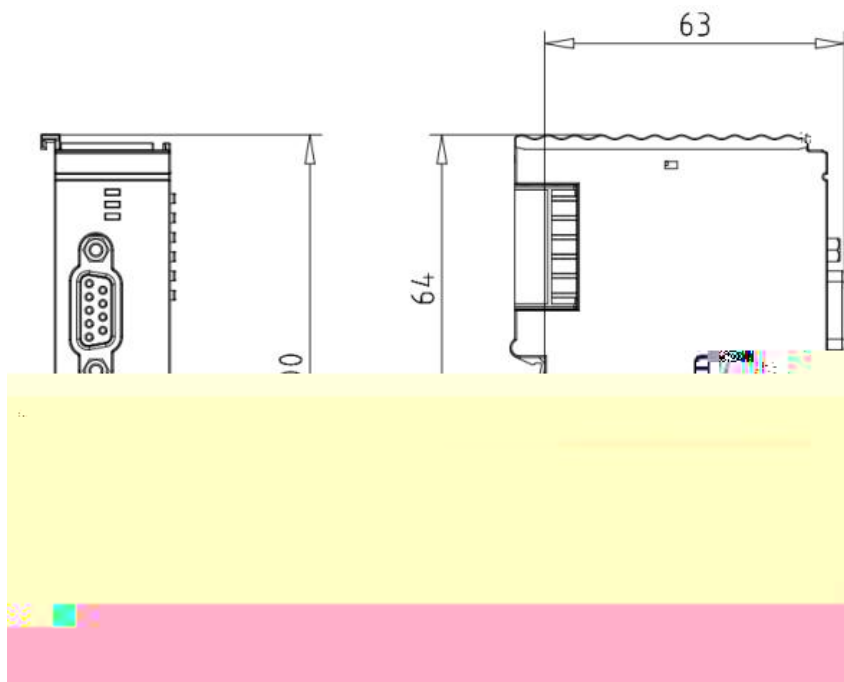

LX-CM001 2 RS-232

8 IO

LX-CM003 2 RS-485

16 IO



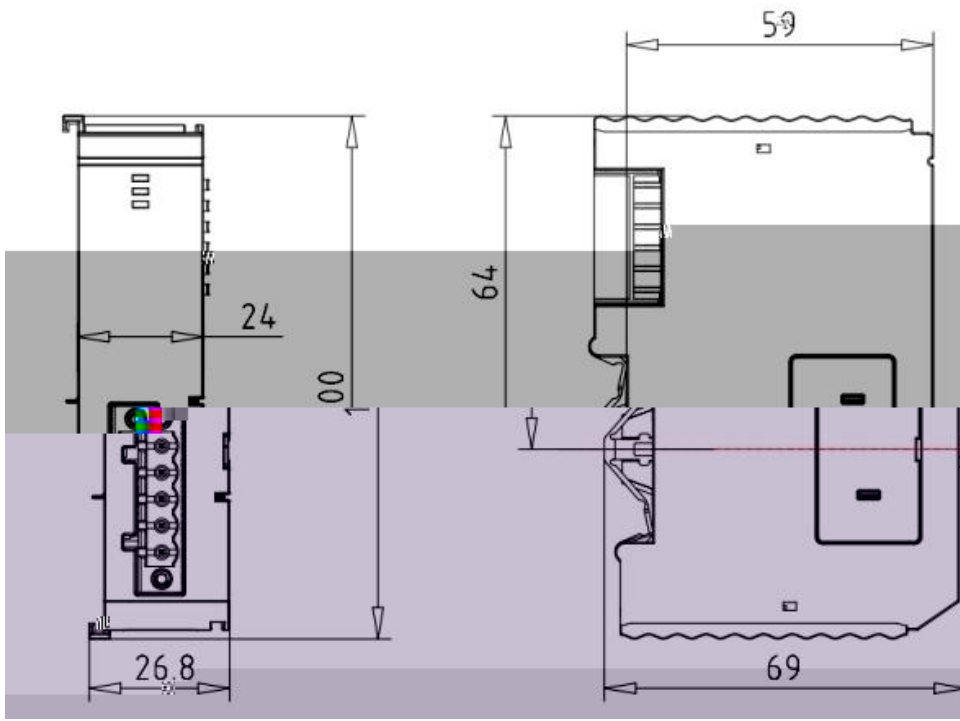

### 1.3.5

1. LX-IM001

mm







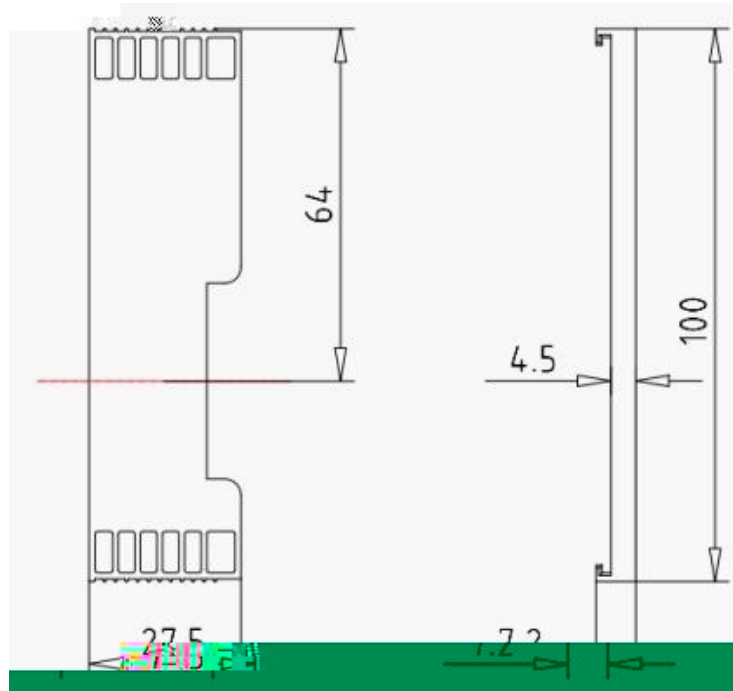

## 1.4

### 1.4.1 CPU

1 DIN

DIN



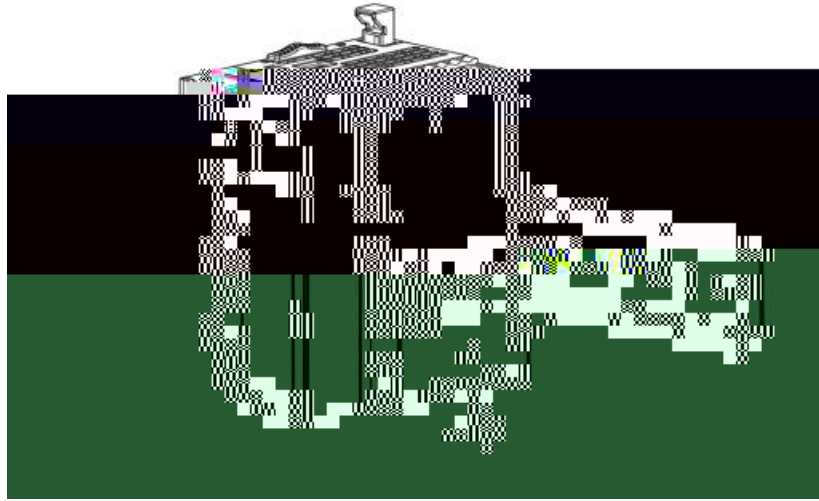

3

DIN

DIN







### 1.4.3

LX-EBK

1



2

DIN



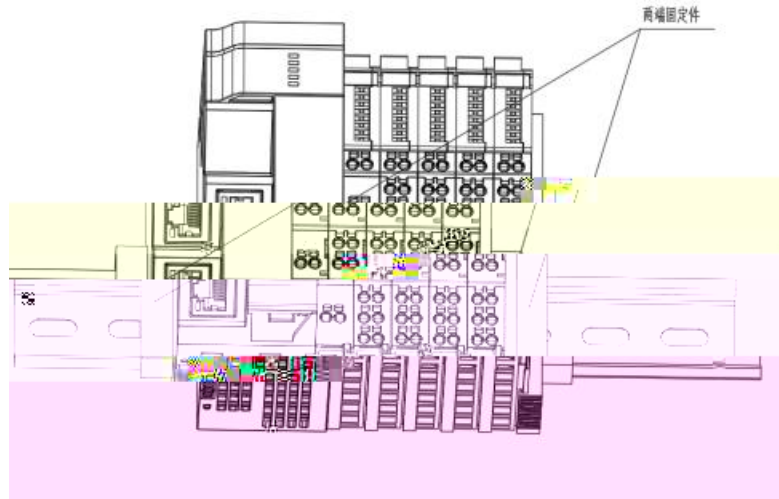

## 1.5

### 1.5.1

150





