

1

**1.**

**2.**

RBC    TSRS

**3.**

1		1	4
2		2	RBC

**RBC**

CTCS-3

RBC

RBC

$T_{RBC-RBC}$

$k \in [0,1]$

0.5

0.6

RBC-RBC

RBC-RBC

RBC

$T_{RBC-RBC}$

RBC



2

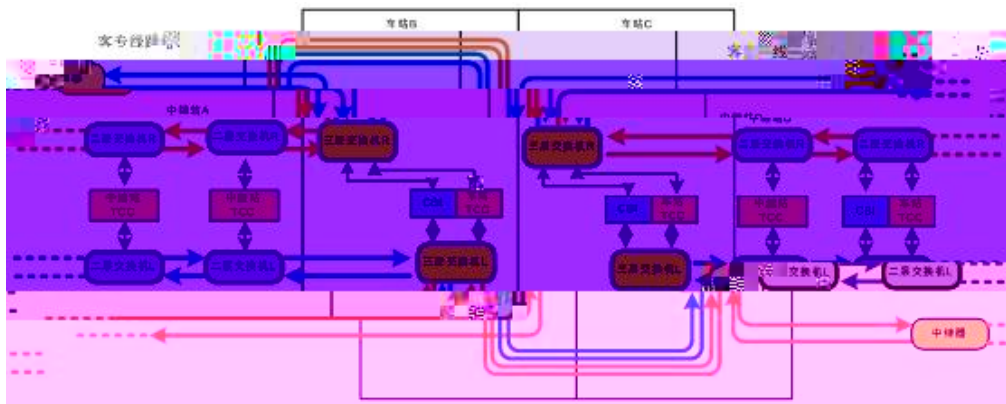

RBC TSRS

RBC

RBC

RBC



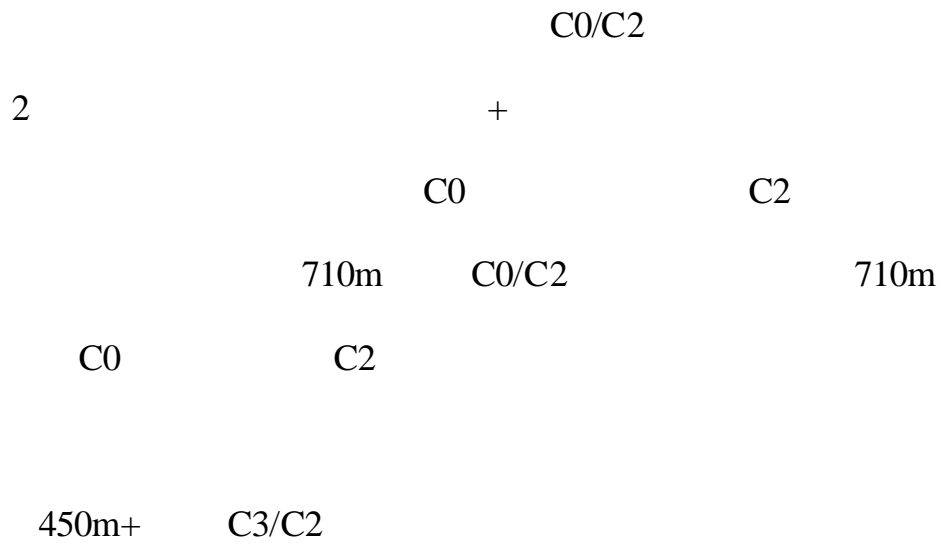

CTCS3+ATO

CTCS-4D

CTCS-4

	RBC		ZL 2017 1 0614194.8	2019 8 13	3492738			
			ZL 2017 1 0370222.6	2019 10 29	3575638			
			ZL 2017 2 0907140.6	2018 4 13	7206334			
			ZL 2017 2 0632819.9	2017 12 26	6773589			
			ZL 2017 2 0655412.8	2018 2 23	7001394			

					1 2 3 4 RBC TSRS
					1 2
					1 2 3

--	--	--	--	--	--	--

1

2

RBC







					RBC TSRS
					RBC TSRS RBC TSRS

--	--

